

# [STN-L32D Option Stand]

## NOTES

1. APPROVAL OF EACH SUB-ITEM IS REQUIRED BEFORE ASSEMBLY.
2. REFER TO THE CODE NO. TABLE FOR SPECIFICATION OF EACH SUB-ITEMS.
3. PACK EACH ASSEMBLY SO AS TO BE OUT OF DEFORMATION DURING DELIVERY.
4. APPROVAL IS REQUIRED BEFORE MANUFACTURING.
5. NO DEFECTS IN THE OUTER SURFACE IS ALLOWABLE.

Rev. No	Code	Revision	Remarks
00	A	RELEASED	

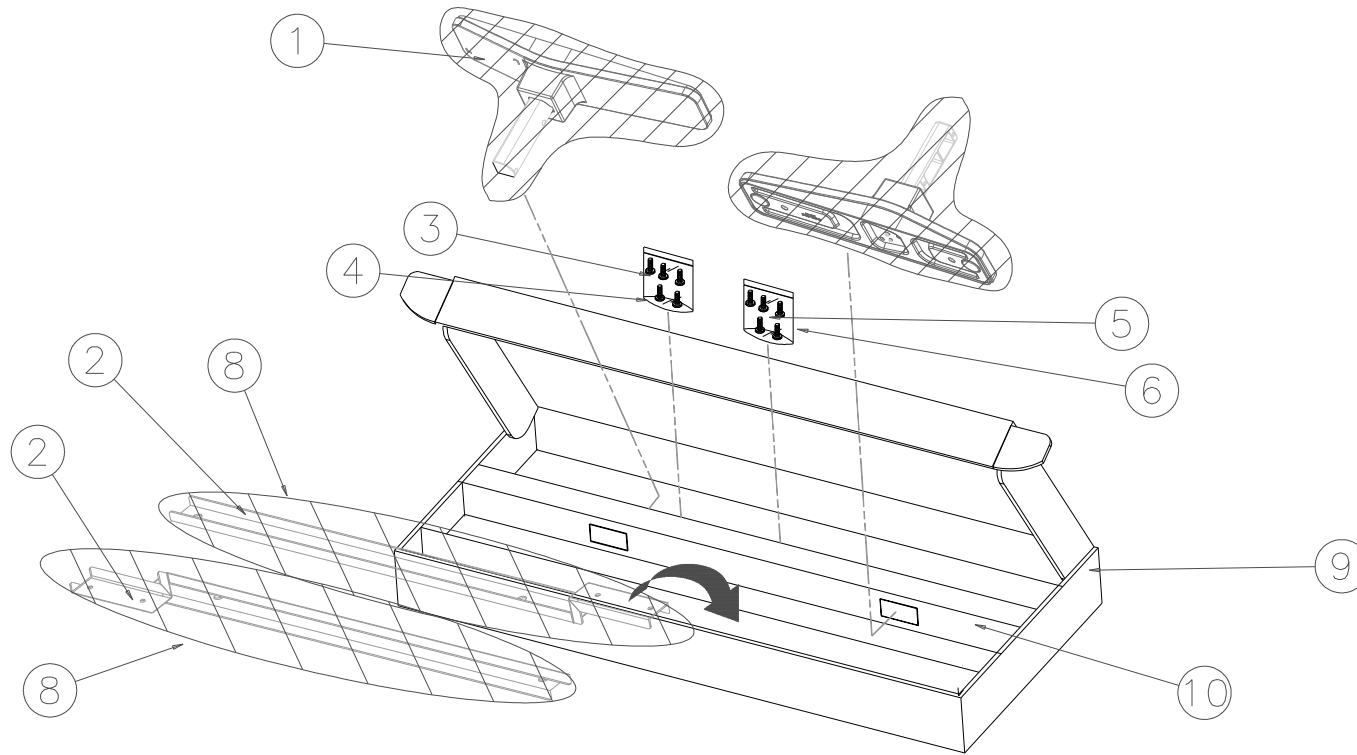

MODEL-NAME	NO	PART NAME	CODE NO.	SPEC.	Q'TY	ASSY-CODE
STN-L32D	10	PAD-TYPE	BN69-05409A	M8, L18, ZPC(BLK), SWRCH18A, WSP, PH	1	ASSY STAND P-SET BN96-16432A
	9	BOX-SET	BN69-05408A	NI TRON, TO.015/TO.5, W1300, L700, TRP.0.0, 3 PE MARK, 28.064g	1	
	8	BAG-SHEET	6902-000539	HDPE/NI TRON, TO.015+TO.5, W600, L250, 2. + HOLE(40mm), 66.000g	2	
	7	MANUAL FLYER-STAND	BN68-03155A	LEDBLU, WW15, Mojo 80g, 210, 148, A3-A5	1	
	6	BAG ZIPPER	6902-000336	LDPE, TO.05, W70, L80, TRP, 0.500g	1	
	5	SCREW-MACHINE	6001-002622	PH, +, WSP, M6, L12, ZPC(BLK), SWRCH18A	5	
	4	BAG ZIPPER	6902-000336	LDPE, TO.05, W70, L80, TRP, 0.500g	1	
	3	SCREW-TAPTYP	6003-000337	BH, +, S, M4, L10, ZPC(BLK), SWRCH18	5	
	2	BRACKET-STAND	BN61-07086A	320MX-3, SECC, 1.6T, BLACK, SPRAY	2	
	1	ASSY STAND P	BN96-16431A	STN-L3255D	2	

## STAND SPEC

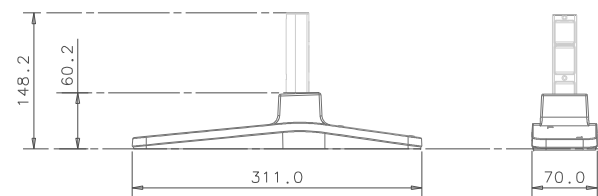

WEIGHT(1EA) : 0.7Kg

TITLE										STN-L32D	
UNIT	MM	DESIGNED	CHECKED	APPROVED	PROJECT	STN-L32D					
SCALE	1/1.5	W. J. BAEK									
Doc. CODE											